

宁波欧乐机械有限公司
NINGBO OULE MACHINE CO., LTD.

宁波德克刀具有限公司
NINGBO DEREK TOOLS CO.,LTD.

营销总部 SALES CENTER

地址: 浙江省宁波市鄞州区鄞县大道1357号广博国贸中心23楼
Add: 23th Floor, Guangbo Bld, No.1357, Middle section of Yinxian Ave, Yinzhou, Ningbo, Zhejiang
电话/ Tel: 0574-26286999 26287770/71/73/76
传真/ Fax: 0574-26283999
邮箱/ E-mail: sales@derekmetal.com
网址/ Web: www.derekmetal.com

国际贸易 OVERSEAS

电话/ Tel: +86-574-26287772
邮箱/ E-mail: sales1@derekmetal.com
网址/ Web: www.derektools.com

江苏分部 JIANGSU BRANCH

电话/ Tel: 0512-57777308 57777309
传真/ Fax: 0512-57777309

广东分部 GUANGDONG BRANCH

电话/ Tel: 0769-81199996 85305802
传真/ Fax: 0769-81199995

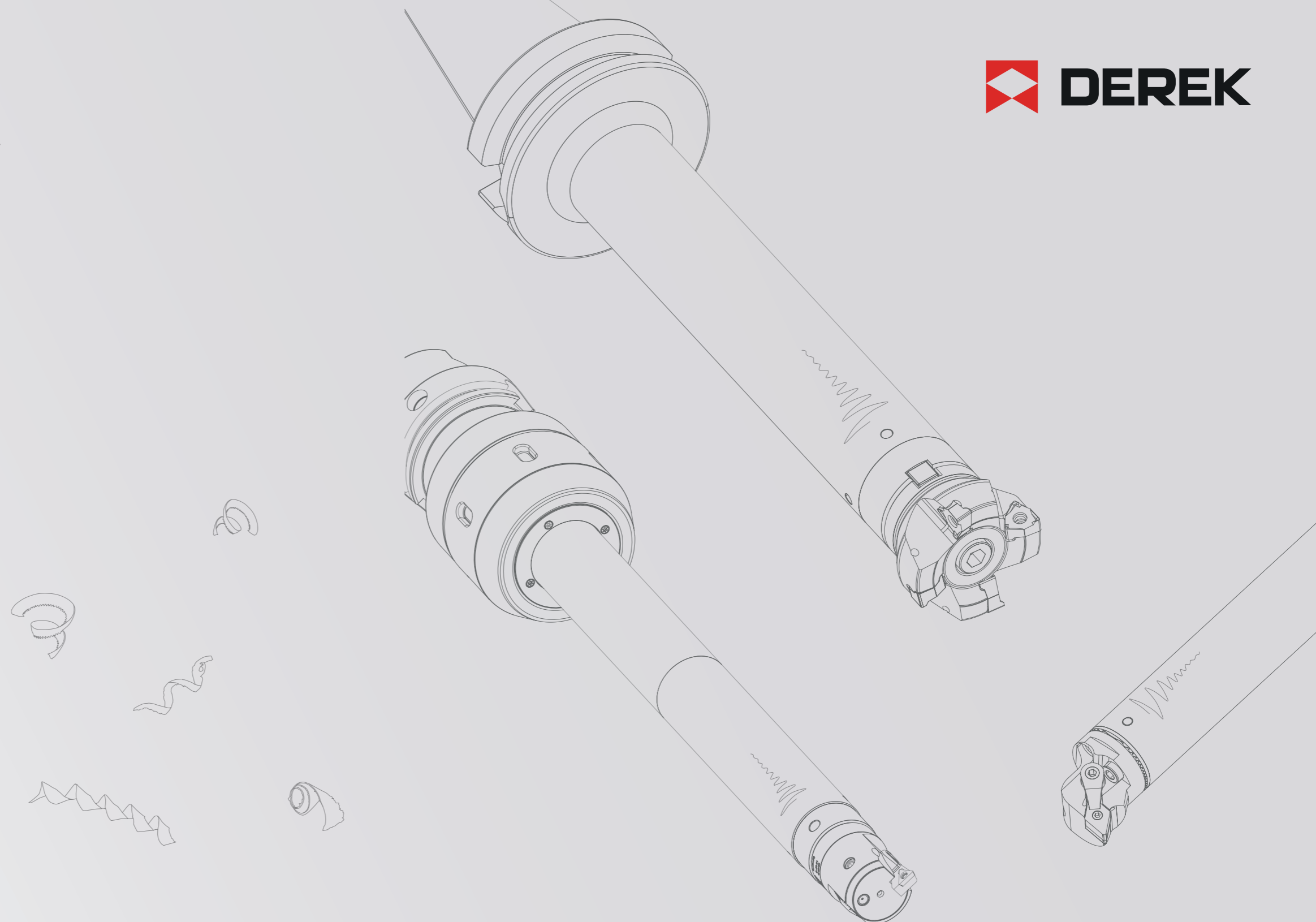

我们保留技术更新、改善产品权利
We reserve the rights to update the products
specification without prior notice.

**ANTI-VIBRATION
SYSTEM**



ABOUT DEREK

德克简介

宁波欧乐机械有限公司及宁波德克刀具有限公司为“DEREK”刀具品牌在国内的制造加工企业及营销中心，并在中国宁波设有占地 25 亩的一期工厂加工区及占地 30 亩的二期工厂加工区。

公司自 1993 年成立至今，20 多年专注于研发，是国内极少数拥有完整数控刀具现代化生产线的制造企业，拥有 30 多项核心专利，多项国际认证，享誉海内外客户及业内同行！

Ningbo Oule Machine Co., Ltd., established in 1993, is the research and manufacturing center of Derek Tools and specialized in CNC milling cutters, turning tools, tool holders, and boring tools. Our mission is to provide high quality products and a-class service, including providing our customers with tools solution, helping them get smooth production.



工厂1
Factory I



工厂2
Factory II



工厂3
Factory III



检测部
Testing Dept.

德克刀具每款产品都承载着“制造一流产品、提供一流服务”企业宗旨，“为客户提供数控刀具整体解决方案、助其更好的服务市场以获得全球性的成功”是德克刀具的企业诉求。

通过不断技术革新，德克刀具客户遍布70多个国家和地区，建立了初步的全球营销网络！通过大量专业人才和先进的高科技生产检测设备，在先进管理理念和国际质量体系的引导下，通过公司全体员工的智慧和不断辛勤努力开发的德克刀具以其新颖的结构、精湛的工艺、优越的性能，德克刀具获得了客户的一致好评和广泛认同。

We work with the most experienced engineers in high precise tools area, and we have the testing equipments to make sure our tools are qualified. During the past years, we focused on the further development, working with high-tech research institutions all over the world. With our efforts, we won an award of patent of 0.002mm precision adjustmet for FBH micro boring tools.

Meanwhile, we improved the whole factory management level. Today, Derek enjoys good reputation among the CNC tools field.



高新技术企业



DCK-SCBH Anti-vibration Finish Boring
DCK-SCBH 阻尼减振精镗刀



B02

SDCK Anti-vibration Extension
SDCK 阻尼减振延长杆



B02

BT-SDCK Anti-vibration Boring Adapter
BT-SDCK 阻尼减振镗刀柄



B03

SCB-SDCK Anti-vibration Boring Bar
SCB-SDCK 阻尼减振直柄镗刀杆



B03

BT-SFMB Anti-vibration Face Mill Holder
BT-SFMB 阻尼减振平面铣刀柄



B04

MCLNR/L Anti-vibration Turning Tool Head
MCLNR/L 阻尼减振车刀头



B05

MDUNR/L Anti-vibration Turning Tool Head
MDUNR/L 阻尼减振车刀头



B05

MVUNR/L Anti-vibration Turning Tool Head
MVUNR/L 阻尼减振车刀头



B06

SCLCR/L Anti-vibration Turning Tool Head
SCLCR/L 阻尼减振车刀头



B06

SDUCR/L Anti-vibration Turning Tool Head
SDUCR/L 阻尼减振车刀头



B07

SVUCR/L Anti-vibration Turning Tool Head
SVUCR/L 阻尼减振车刀头



B07

SVLCR/L Anti-vibration Turning Tool Head
SVLCR/L 阻尼减振车刀头



B08

SDPCR/L Anti-vibration Turning Tool Head
SDPCR/L 阻尼减振车刀头



B08

SDZCR/L Anti-vibration Turning Tool Head
SDZCR/L 阻尼减振车刀头



B09

SVZCR/L Anti-vibration Turning Tool Head
SVZCR/L 阻尼减振车刀头



B09

MCLNR/L Anti-vibration Turning Tool Head
MCLNR/L 阻尼减振车刀头



B10

MDUNR/L Anti-vibration Turning Tool Head
MDUNR/L 阻尼减振车刀头



B10

MDZNR/L Anti-vibration Turning Tool Head
MDZNR/L 阻尼减振车刀头



B11

MDPNR/L Anti-vibration Turning Tool Head
MDPNR/L 阻尼减振车刀头



B11

MVZNR/L Anti-vibration Turning Tool Head
MVZNR/L 阻尼减振车刀头



B12

SDUCR/L Anti-vibration Turning Tool Head
SDUCR/L 阻尼减振车刀头



B12

SVLCR/L Anti-vibration Turning Tool Head
SVLCR/L 阻尼减振车刀头



B13

SDV Anti-vibration Turning Tool Holder
SDV 阻尼减振车刀杆



B13

SDV Anti-vibration Turning Tool Holder
SDV 阻尼减振车刀杆



B14

SDV Anti-vibration Turning Tool Holder
SDV 阻尼减振车刀杆



B14

Anti-vibration Reducing Head
阻尼减振车刀缩径头



B15

Centre Calibration Block
中心校准块



B15

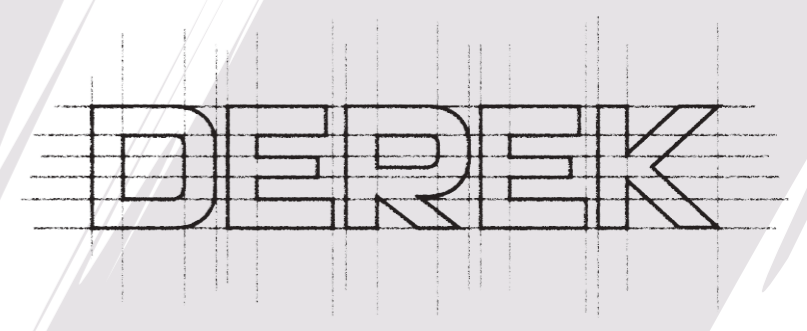



DCK-SCBH/SDCK/BT-SDCK/SCB-SDCK

DCK-SCBH/SDCK/BT-SDCK/SCB-SDCK Anti-vibration Boring System
DCK-SCBH/SDCK/BT-SDCK/SCB-SDCK 阻尼减振镗刀系列

Various Structural Forms
结构形式丰富

满足多元化镗孔需求/Meet Diversified Machining Needs



SCBH 精镗刀 SCBH Finish Boring

■ 镗头搭载减振机构, CBH 精镗头的功能保持不变, 并且与减振机构融为一体;

■ The boring head is equipped with vibration reduction, The function of CBH finish boring head remains unchanged, and they are syncretized with each other.

SDCK 镗刀柄 SDCK Boring Adaptor

■ DCK 基础柄内置减振机构, 为更长倍径保驾护航;

■ Vibration reduction attached on DCK boring adaptor could receive better machining result during deep hole machining.

SDCK 延长杆 SDCK Extension

■ 内置减振机构, 两端 DCK 接口, 与现有标准镗头、基础柄实现互联互通;

■ Smoothly interconnecting with existing standard boring head and boring adaptor by DCK connector and vibration reduction.

SCB-SDCK 直柄镗刀杆 SCB-SDCK Boring Bar

■ 内置减振机构, 前端 DCK 接口, 后端配合各主轴形式的强力刀柄, 满足小孔径镗孔长倍径需求。

■ Vibration reduction attached, DCK boring adaptor at the front and power chucks with various cone at the back. And it also meets the needs of small but deep hole machining.

Contrast Experiment 实测性能对比

切削条件

机床: 立加
加工直径: $\Phi 54$
刀尖半径: R0.2
进给: 0.1mm/rew
切削量: 0.3mm/ Φ

Machining Condition

Machine: Vertical machining center
Cutting dia: $\Phi 54$
Radius: R0.2
Feed: 0.1mm/rew
Cutting output: 0.3mm/ Φ

42CrMo (HRC40) 精镗加工 Finish Boring

× 振动 ○ 稳定 ◎ 优越 × Vibrating ○ Steady ◎ Superior

组合型号 Specification	50	80	100	150
BBT50-DCK5-263 DCK5-CBH53-95 (L/D=5.8)	○	×	×	×
BBT50-DCK5-263 DCK5-SCBH53-215 (L/D=8.6)	○	○	○	◎

DCK-SCBH/SDCK

DCK-SCBH Anti-vibration Finish Boring
DCK-SCBH 阻尼减振精镗刀

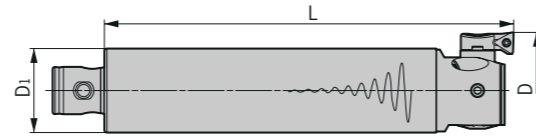
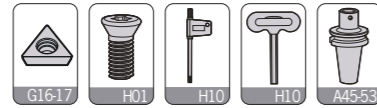

型号 Specification	D ₁	L	范围 Boring range	组合刀柄 Adapter size	刀片座 Cartridge	刀片 Insert	螺钉 Screw	扳手 Wrench	重量 Weight
DCK1-SCBH20-110	19	110	20-26	DCK1	CBH1-1				0.29
DCK2-SCBH25-130	24	130	25-33	DCK2	CBH2-1	TPGH0802	M020D055	Q06	0.55
DCK3-SCBH32-150	31	150	32-42	DCK3	CBH3-1				1.09
DCK4-SCBH41-190	39	190	41-54	DCK4	CBH4-1				2.08
DCK5-SCBH53-215	50	215	53-70	DCK5	CBH5-1	TCMT1102 (标配With)			3.86
DCK6-SCBH68-245	64	245	68-100	DCK6	CBH6-1	TPGH1103 (选配)	M025W060 M030W070	Q08	7.73 11.73
DCK7-SCBH100-245	90	245	100-153	DCK7	CBH6-1				11.73
	90	245	126-179	DCK7	CBH6-2				11.73
	90	245	150-203	DCK7	CBH6-3	(For choice)			11.73

SDCK Anti-vibration Extension
SDCK 阻尼减振延长杆

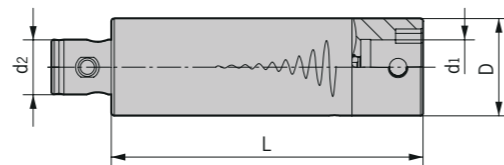
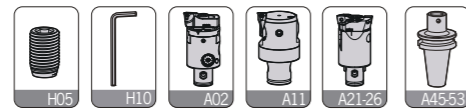

型号 Specification	D	d ₁	d ₂	L	侧固螺钉 Side-lock screw	L型扳手 Wrench	重量 Weight
SDCK2-2-90	24	14	14	90	M050Z060-30P-D	L025	0.33
SDCK3-3-115	31	18	18	115	M060Z090-30P-D	L03	0.75
SDCK4-4-125	39	22	22	125	M080Z120-30P-D	L04	1.14
SDCK5-5-155	50	28	28	155	M100Z160-30P-D	L05	2.39
SDCK6-6-185	64	36	36	185	M120Z200-30P-D	L06	5.11

BT-SDCK/SCB-SDCK

BT-SDCK Anti-vibration Boring Adapter
BT-SDCK 阻尼减振镗刀柄

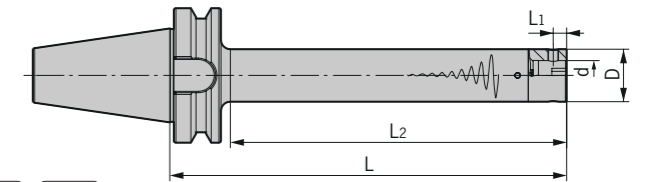
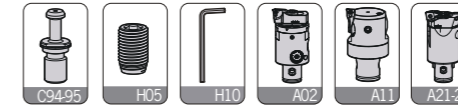

型号 Specification	D	d	L ₁	L ₂	L	侧固螺钉 Side-lock screw	L型扳手 Wrench	重量 Weight
BT40-SDCK2-145	24	14	6.45	110	145	M050Z060-30P-D	L025	1.44
BT40-SDCK2-170	24	14	6.45	135	170	M050Z060-30P-D	L025	1.54
BT40-SDCK2-195	24	14	6.45	160	195	M050Z060-30P-D	L025	1.64
BT40-SDCK3-195	31	18	7.9	160	195	M060Z090-30P-D	L03	2.15
BT40-SDCK3-225	31	18	7.9	190	225	M060Z090-30P-D	L03	2.37
BT40-SDCK3-255	31	18	7.9	220	255	M060Z090-30P-D	L03	2.59
BT40-SDCK4-240	39	22	10	205	240	M080Z120-30P-D	L04	3.07
BT40-SDCK4-280	39	22	10	245	280	M080Z120-30P-D	L04	3.50
BT40-SDCK4-320	39	22	10	285	320	M080Z120-30P-D	L04	3.93
BT40-SDCK5-315	50	28	13	283	315	M100Z160-30P-D	L05	5.65
BT50-SDCK2-165	24	14	6.45	117	165	M050Z060-30P-D	L025	4.12
BT50-SDCK2-190	24	14	6.45	142	190	M050Z060-30P-D	L025	4.22
BT50-SDCK2-215	24	14	6.45	167	215	M050Z060-30P-D	L025	4.32
BT50-SDCK3-205	31	18	7.9	160	205	M060Z090-30P-D	L03	4.80
BT50-SDCK3-235	31	18	7.9	190	235	M060Z090-30P-D	L03	5.02
BT50-SDCK3-265	31	18	7.9	220	265	M060Z090-30P-D	L03	5.24
BT50-SDCK4-255	39	22	10	210	255	M080Z120-30P-D	L04	5.89
BT50-SDCK4-295	39	22	10	250	295	M080Z120-30P-D	L04	6.27
BT50-SDCK4-335	39	22	10	290	335	M080Z120-30P-D	L04	6.65
BT50-SDCK5-315	50	28	13	270	315	M100Z160-30P-D	L05	8.51
BT50-SDCK5-360	50	28	13	315	360	M100Z160-30P-D	L05	9.30
BT50-SDCK5-405	50	28	13	360	405	M100Z160-30P-D	L05	10.09
BT50-SDCK6-380	64	36	16	335	380	M120Z200-30P-D	L06	12.56
BT50-SDCK6-445	64	36	16	400	445	M120Z200-30P-D	L06	14.24
BT50-SDCK6-510	64	36	16	465	510	M120Z200-30P-D	L06	15.93

SCB-SDCK Anti-vibration Boring Bar
SCB-SDCK 阻尼减振直柄镗刀杆

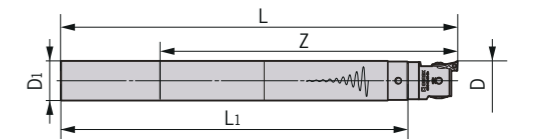
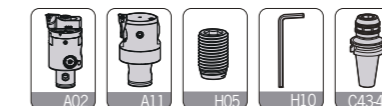

型号 Specification	D ₁	D	有效加工深度 Z	L ₁	L	总重量 Weight
SCB- C19-SDCK1-190			133	190	222	0.43
C19-SDCK1-240	19	20-36	190	240	272	0.77
C24-SDCK2-220			168	220	255	0.79
C24-SDCK2-280	24	25-47	240	280	315	1.43
C32-SDCK3-280			224	280	320	1.78
C32-SDCK3-350	32	33-60	320	350	390	3.24

SFMB

BT-SFMB Anti-vibration Face Mill Holder
BT-SFMB 阻尼减振平面铣刀柄

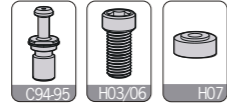
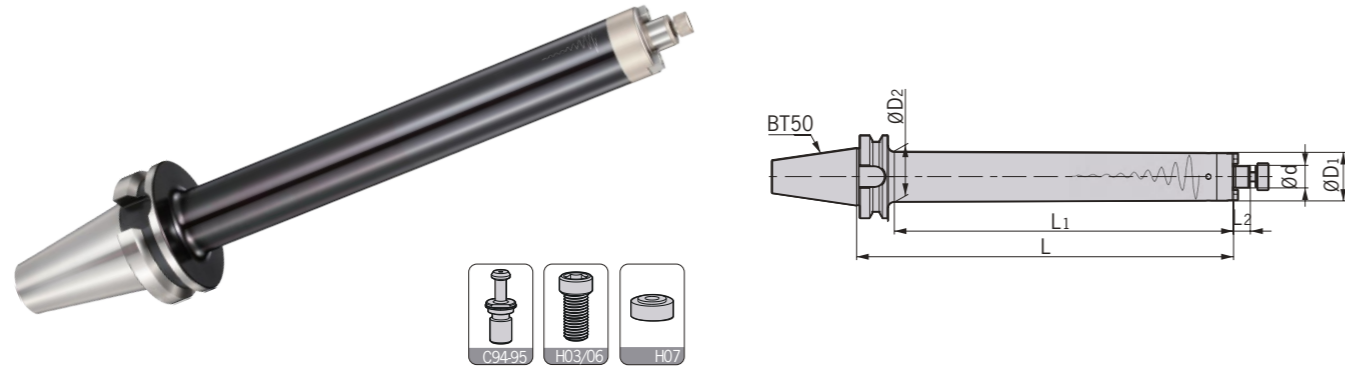

型号 Specification	D ₁	D ₂	d	L	L ₁	L ₂	刀盘锁紧螺钉 Locking screw for cutter	垫圈 Washer	重量 Weight
BT50-SFMB22-D48-300	48	48	22	300	255	18	E100U300	-	7.9
SFMB22-D48-400	48	48	22	400	355	18	E100U300	-	9.3
SFMB22-D58-400	58	61	22	400	355	18	E100U300	-	12.5
SFMB22-D58-500	58	61	22	500	455	18	E100U300	-	14.9
SFMB27-D58-400	58	61	27	400	355	-	E120U300	FM-1	13.7
SFMB27-D58-500	58	61	27	500	455	-	E120U300	FM-1	15.1
SFMB27-D74-500	74	78	27	500	455	-	E120U300	FM-1	21.2
SFMB27-D74-600	74	78	27	600	555	-	E120U300	FM-1	24.9
SFMB32-D74-500	74	78	32	500	455	-	E160U350	FM-2	21.4
SFMB32-D74-600	74	78	32	600	555	-	E160U350	FM-2	25.1

SDV

MCLNR/L Anti-vibration Turning Tool Head
MCLNR/L 阻尼减振车刀头

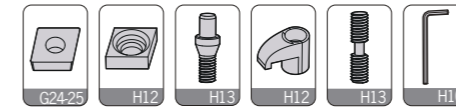
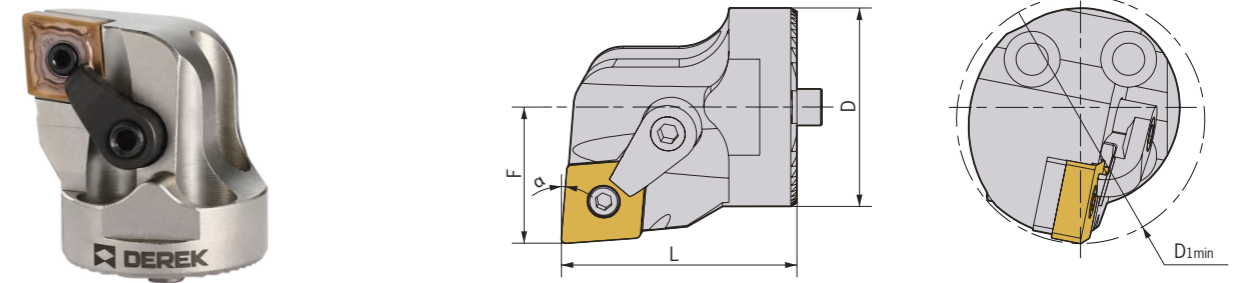

型号 Specification	D	D _{1min}	F	L	α°	刀片型号 Insert	刀垫 Shim	中心螺丝 Center screw	压板 Clamp	压板螺丝 Clamp screw	重量 Weight
SDV32-MCLNR/L-12	32	40	22	38	5°	CN**120408	MC1204	MX0617	MY0619	ML0625	0.13
SDV40-MCLNR/L-12	40	50	27	38	5°	CN**120408	MC1204	MX0617	MY0619	ML0625	0.21

MDUNR/L Anti-vibration Turning Tool Head
MDUNR/L 阻尼减振车刀头

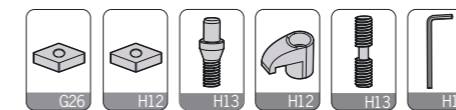
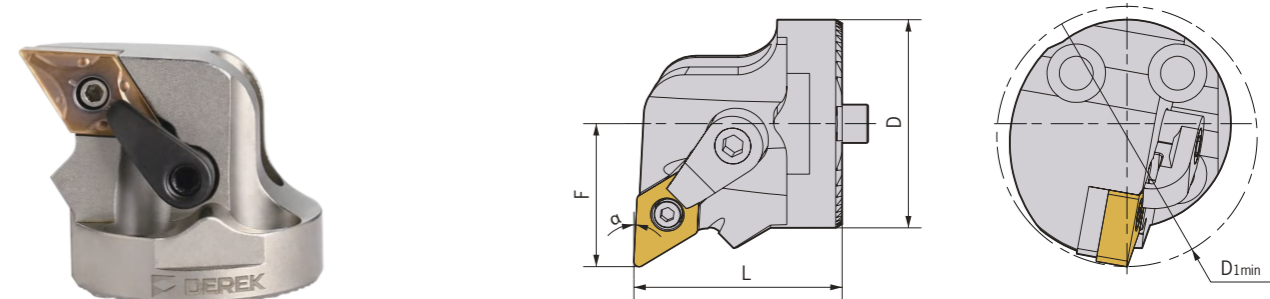

型号 Specification	D	D _{1min}	F	L	α°	刀片型号 Insert	刀垫 Shim	中心螺丝 Center screw	压板 Clamp	压板螺丝 Clamp screw	重量 Weight
SDV32-MDUNR/L-11	32	40	22	32	3°	DN**110408	MD1103	MX0513	MY0619	ML0625	0.11
SDV40-MDUNR/L-15	40	50	27	38	3°	DN**150608	MD1504	MX0619	MY0621	ML0625	0.18

SDV

MVUNR/L Anti-vibration Turning Tool Head
MVUNR/L 阻尼减振车刀头

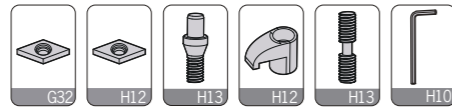
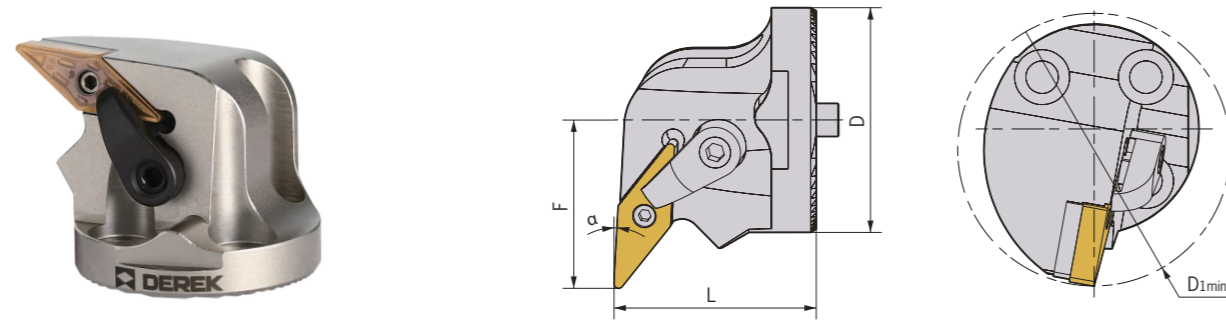

型号 Specification	D	D1min	F	L	α°	刀片型号 Insert	刀垫 Shim	中心螺丝 Center screw	压板 Clamp	压板螺丝 Clamp screw	重量 Weight
SDV40-MVUNR/L-16	40	52	30	36	3°	VN**160408	MV1603	MX0513	MY0621	ML0625	0.20

SDV

SDUCR/L Anti-vibration Turning Tool Head
SDUCR/L 阻尼减振车刀头

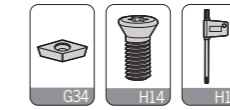
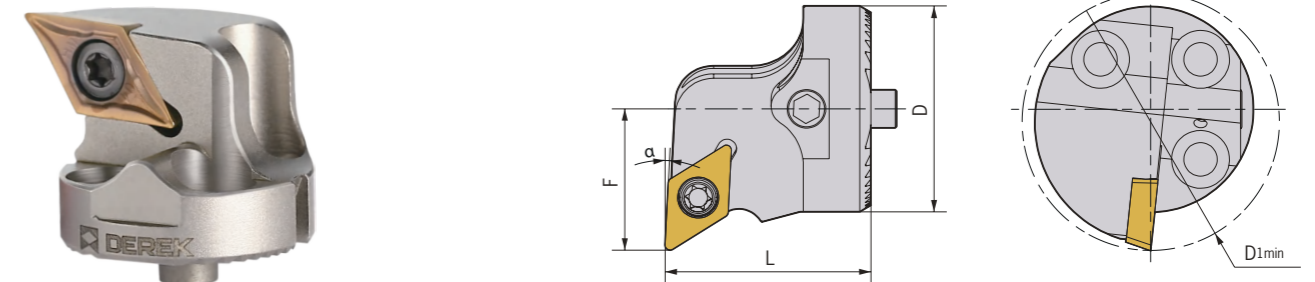

型号 Specification	D	D1min	F	L	α°	刀片型号 Insert	螺丝 Screw	重量 Weight
SDV16-SDUCR/L-07	16	20	11	20	3°	DC**070204	M025W050	0.02
SDV20-SDUCR/L-11	20	25	13	20	3°	DC**11T308	M040S100-1	0.03
SDV25-SDUCR/L-11	25	32	17	22	3°	DC**11T308	M040S100-1	0.05
SDV32-SDUCR/L-11	32	40	22	32	3°	DC**11T308	M040S100-1	0.11
SDV40-SDUCR/L-11	40	50	27	38	3°	DC**11T308	M040S100-1	0.20

SCLCR/L Anti-vibration Turning Tool Head
SCLCR/L 阻尼减振车刀头

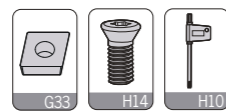
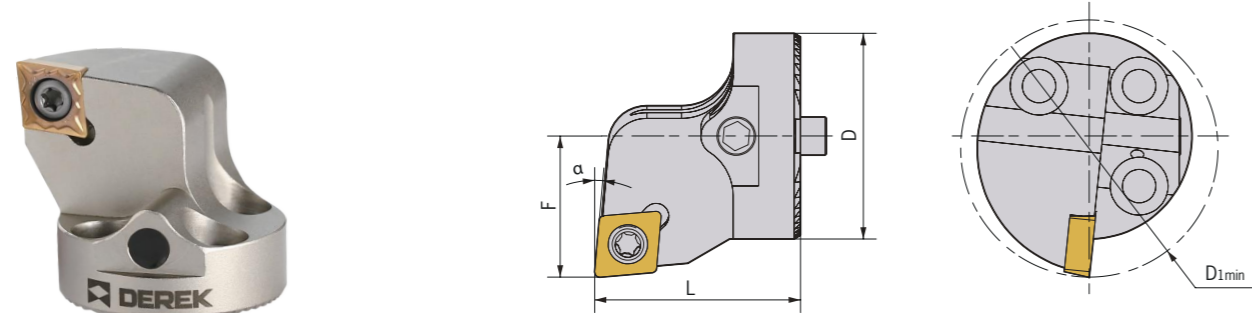

型号 Specification	D	D1min	F	L	α°	刀片型号 Insert	螺丝 Screw	重量 Weight
SDV16-SCLCR/L-06	16	20	11	20	5°	CC**060204	M025W060	0.02
SDV20-SCLCR/L-09	20	25	13	20	5°	CC**09T308	M040S080-1	0.03
SDV25-SCLCR/L-09	25	32	17	22	5°	CC**09T308	M040S080-1	0.05
SDV32-SCLCR/L-09	32	40	22	32	5°	CC**09T308	M040S100-1	0.11
SDV40-SCLCR/L-12	40	50	27	38	5°	CC**120408	M050Y110-1	0.20

SVUCR/L Anti-vibration Turning Tool Head
SVUCR/L 阻尼减振车刀头

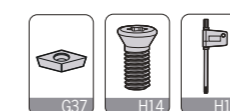
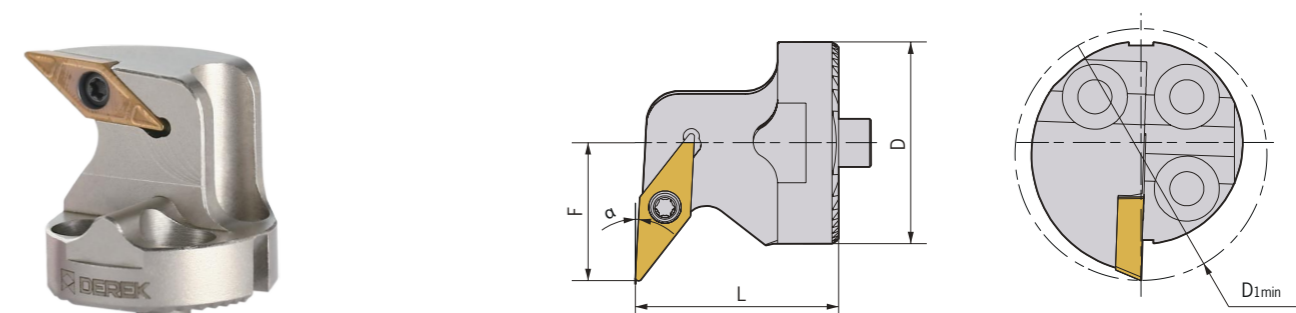

型号 Specification	D	D1min	F	L	α°	刀片型号 Insert	螺丝 Screw	重量 Weight
SDV20-SVUCR/L-11	20	27	16	20	3°	VC**110304	M025W070	0.03
SDV25-SVUCR/L-11	25	31	17	25	3°	VC**110304	M025W070	0.05

SDV

SVLCR/L Anti-vibration Turning Tool Head
SVLCR/L 阻尼减振车刀头

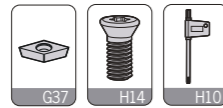
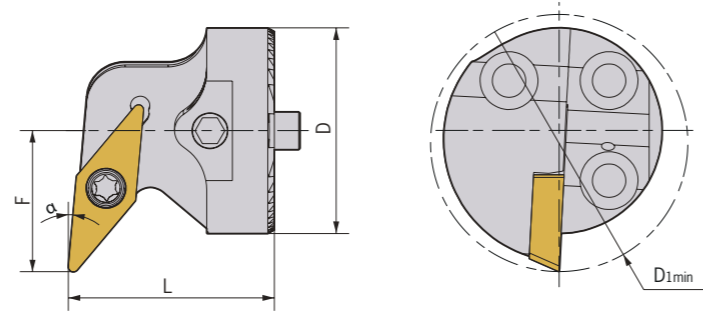

型号 Specification	D	D1min	F	L	α°	刀片型号 Insert	螺丝 Screw	重量 Weight
SDV32-SVLCR/L-16	32	40	22	32	5°	VC**160408	M040S100-1	0.10
SDV40-SVLCR/L-16	40	50	27	32	5°	VC**160408	M040S100-1	0.15

SDV

SDZCR/L Anti-vibration Turning Tool Head
SDZCR/L 阻尼减振车刀头

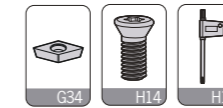
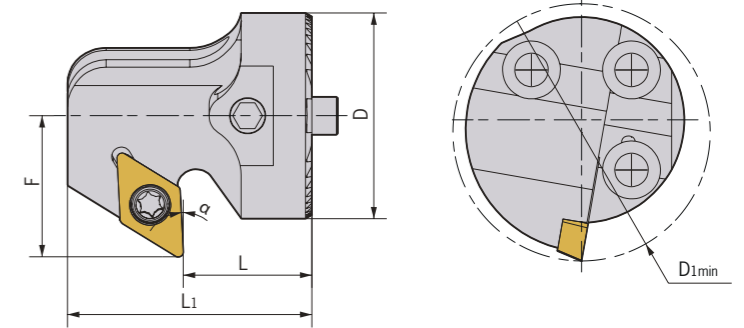

型号 Specification	D	D1min	F	L	L1	α°	刀片型号 Insert	螺丝 Screw	重量 Weight
SDV16-SDZCR/L-07	16	22	13	15	27	3°	DC**070204	M025W050	0.03
SDV20-SDZCR/L-07	20	27	15	15	27	3°	DC**070204	M025W050	0.04
SDV25-SDZCR/L-07	25	33	18	15	27	3°	DC**070204	M025W050	0.06
SDV32-SDZCR/L-11	32	40	22	20	38	3°	DC**11T308	M040S100-1	0.13
SDV40-SDZCR/L-11	40	50	27	20	38	3°	DC**11T308	M040S100-1	0.20

SDPCR/L Anti-vibration Turning Tool Head
SDPCR/L 阻尼减振车刀头

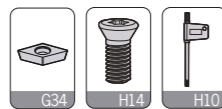
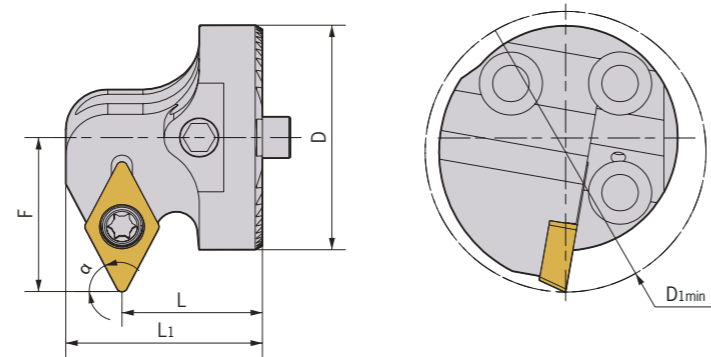

型号 Specification	D	D1min	F	L	L1	α°	刀片型号 Insert	螺丝 Screw	重量 Weight
SDV16-SDPCR/L-07	16	22	13	15	19	62.5°	DC**070204	M025W050	0.02
SDV20-SDPCR/L-07	20	27	15	15	19	62.5°	DC**070204	M025W050	0.03
SDV25-SDPCR/L-07	25	33	18	15	19	62.5°	DC**070204	M025W050	0.04
SDV32-SDPCR/L-11	32	40	22	20	28	62.5°	DC**11T308	M040S100-1	0.09
SDV40-SDPCR/L-11	40	50	27	20	28	62.5°	DC**11T308	M040S100-1	0.15

SVZCR/L Anti-vibration Turning Tool Head
SVZCR/L 阻尼减振车刀头

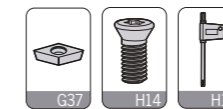
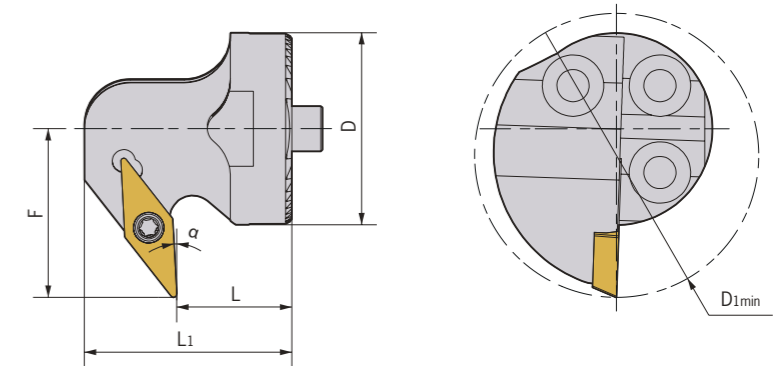

型号 Specification	D	D1min	F	L	L1	α°	刀片型号 Insert	螺丝 Screw	重量 Weight
SDV20-SVZCR/L-11	20	32	20	15	27	3°	VC**110304	M025W070	0.04
SDV25-SVZCR/L-11	25	37	22	15	27	3°	VC**110304	M025W070	0.06

SDV

MCLNR/L Anti-vibration Turning Tool Head
MCLNR/L 阻尼减振车刀头

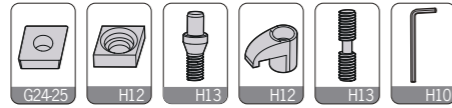
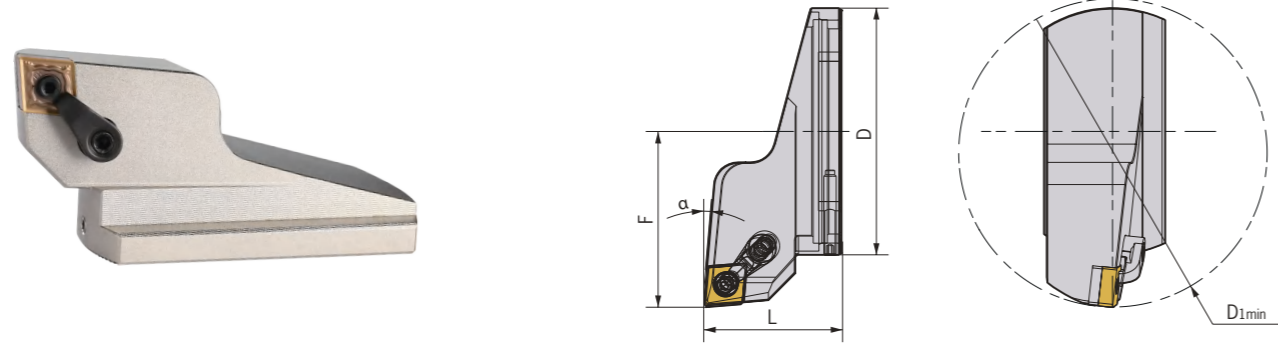

型号 Specification	D	D _{1min}	F	L	α°	刀片型号 Insert	刀垫 Shim	中心螺丝 Center screw	压板 Clamp	压板螺丝 Clamp screw	重量 Weight
SDV80-MCLNR/L-12	80	100	57	45	5°	CN**120408	MC1204	MX0617	MY0619	ML0625	0.50

SDV

MDZNR/L Anti-vibration Turning Tool Head
MDZNR/L 阻尼减振车刀头

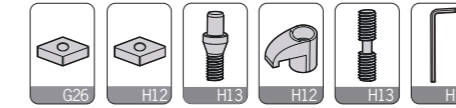
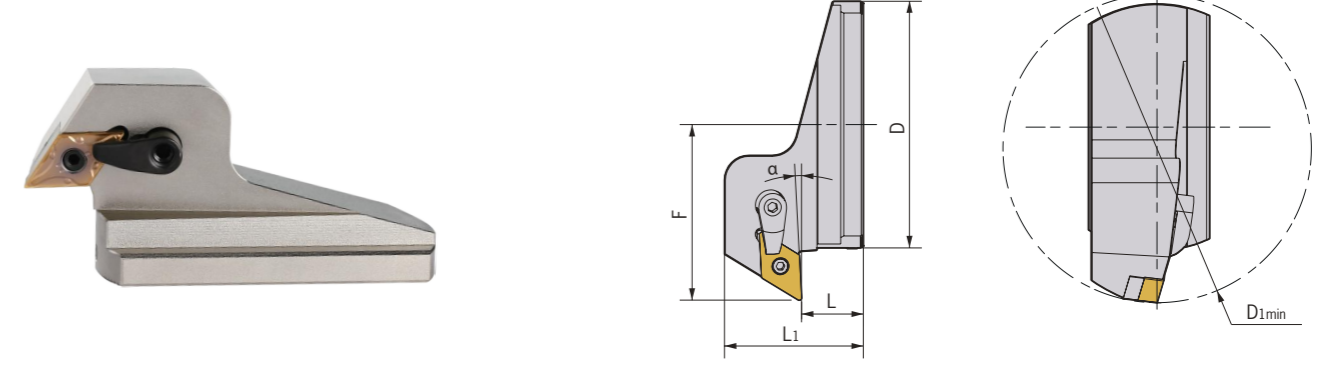

型号 Specification	D	D _{1min}	F	L	L ₁	α°	刀片型号 Insert	刀垫 Shim	中心螺丝 Center screw	压板 Clamp	压板螺丝 Clamp screw	重量 Weight
SDV80-MDZNR/L-15	80	100	57	20	45	3°	DN**150608	MD1504	MX0619	MY0621	ML0625	0.49

MDUNR/L Anti-vibration Turning Tool Head
MDUNR/L 阻尼减振车刀头

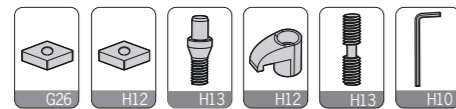
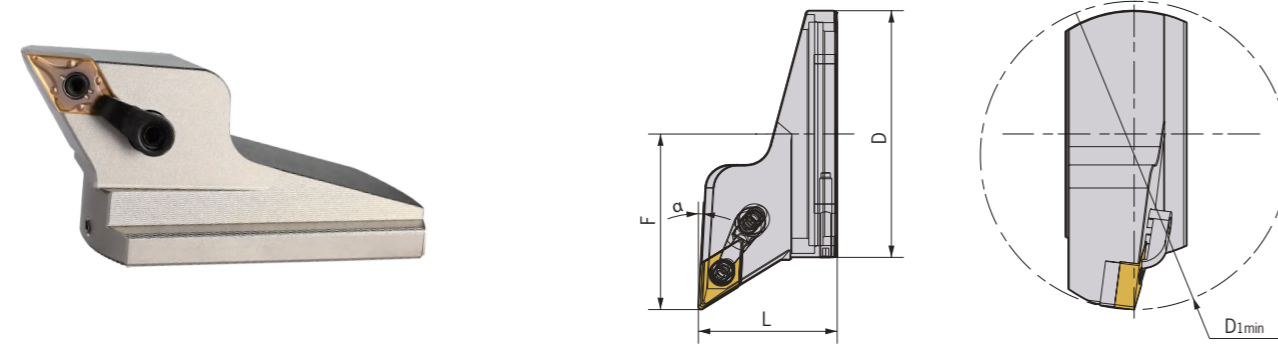

型号 Specification	D	D _{1min}	F	L	α°	刀片型号 Insert	刀垫 Shim	中心螺丝 Center screw	压板 Clamp	压板螺丝 Clamp screw	重量 Weight
SDV80-MDUNR/L-15	80	100	57	45	3°	DN**150608	MD1504	MX0619	MY0621	ML0625	0.48

MDPNR/L Anti-vibration Turning Tool Head
MDPNR/L 阻尼减振车刀头

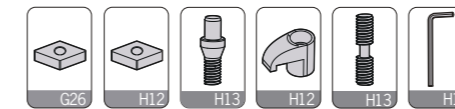
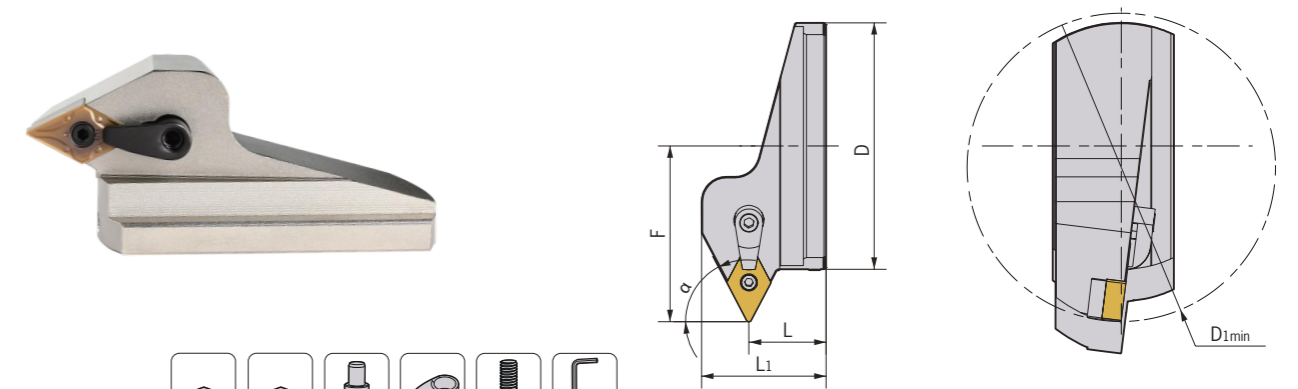

型号 Specification	D	D _{1min}	F	L	L ₁	α°	刀片型号 Insert	刀垫 Shim	中心螺丝 Center screw	压板 Clamp	压板螺丝 Clamp screw	重量 Weight
SDV80-MDPNR/L-15	80	100	57	25	40.3	62.5°	DN**150608	MD1504	MX0619	MY0621	ML0625	0.43

SDV

MVZNR/L Anti-vibration Turning Tool Head
MVZNR/L 阻尼减振车刀头

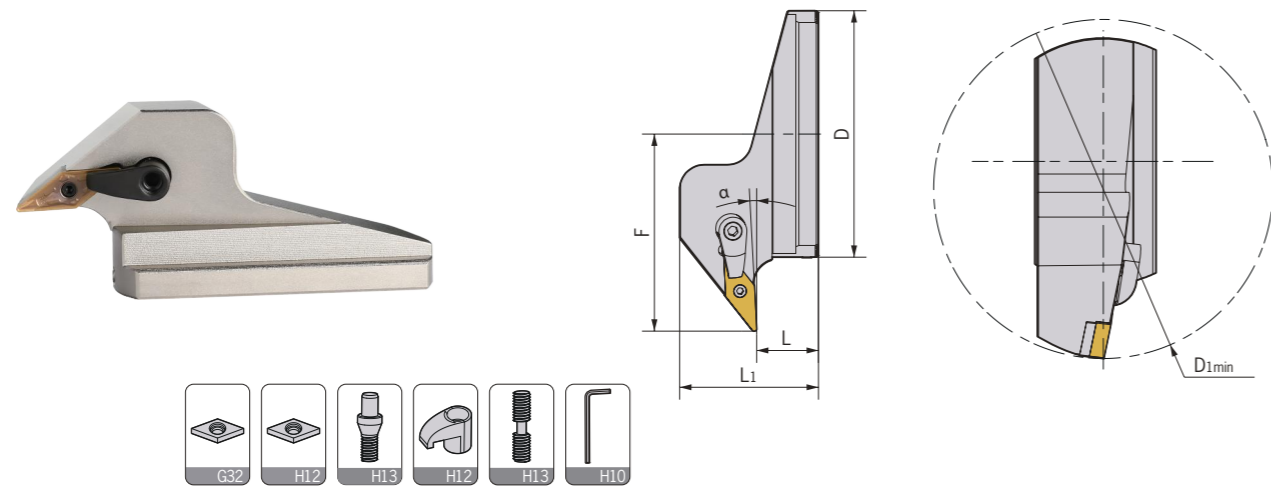

型号 Specification	D	D1min	F	L	L1	α°	刀片型号 Insert	刀垫 Shim	中心螺丝 Center screw	压板 Clamp	压板螺丝 Clamp screw	重量 Weight
SDV80-MVZNR/L-16	80	110	64	20	45	3°	VN**160408	MV1603	MX0513	MY0621	ML0625	0.51

SDV

SVLCR/L Anti-vibration Turning Tool Head
SVLCR/L 阻尼减振车刀头

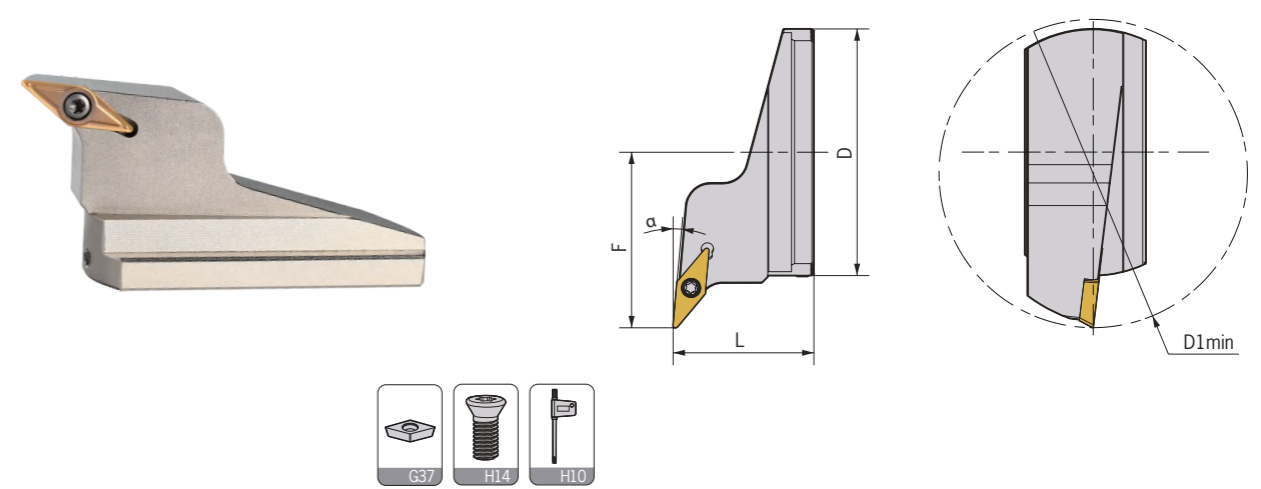

型号 Specification	D	D1min	F	L	α°	刀片型号 Insert	螺丝 Screw	重量 Weight
SDV80-SVLCR/L-16	80	100	57	45.7	5°	DC**11T308	M040S100-1	0.47

SDUCR/L Anti-vibration Turning Tool Head
SDUCR/L 阻尼减振车刀头

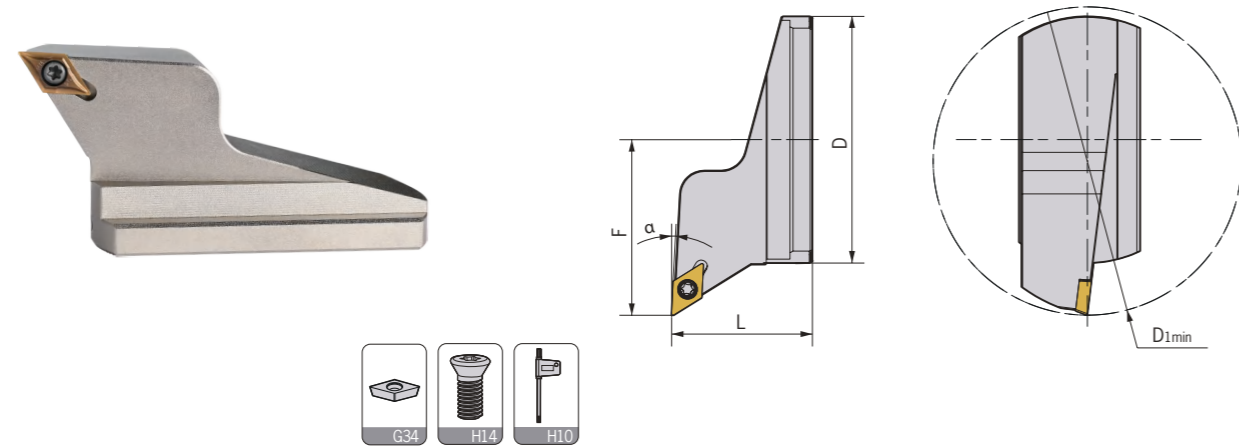

型号 Specification	D	D1min	F	L	α°	刀片型号 Insert	螺丝 Screw	重量 Weight
SDV80-SDUCR/L-11	80	100	57	45.7	3°	DC**11T308	M040S100-1	0.49

SDV Anti-vibration Turning Tool Holder
SDV 阻尼减振车刀杆

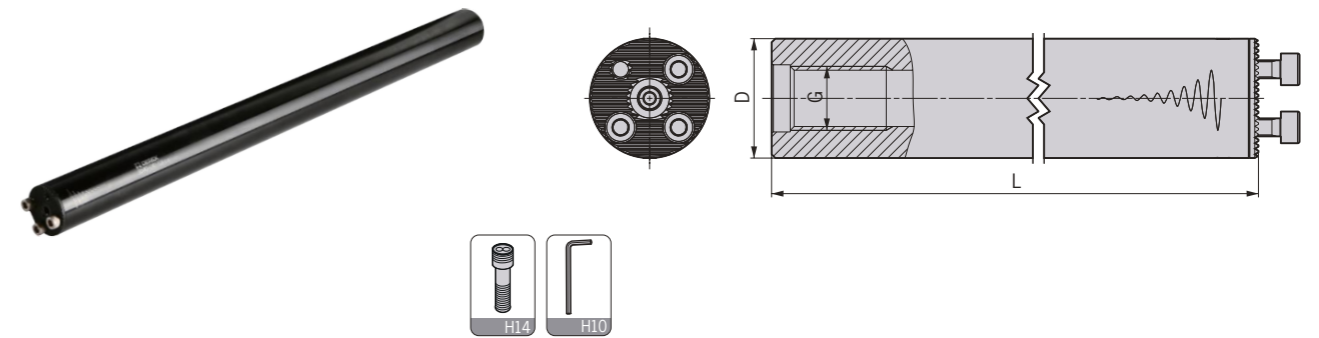

型号 Specification	D	L	G	L/D	适配缩径头 Reducing Head	适配刀头 Head	重量 Weight
SDV16-C16-156	16	156	G1/8"	7	-	SDV16...	0.24
SDV16-C16-204	16	204	/	10	-	SDV16...	0.32
SDV20-C20-200	20	200	G1/4"	7	-	SDV20...	0.46
SDV20-C20-260	20	260	/	10	-	SDV20...	0.62
SDV25-C25-255	25	255	G1/4"	7	-	SDV25...	0.97
SDV25-C25-330	25	330	G1/4"	10	-	SDV25...	1.29
SDV32-C32-320	32	320	G3/8"	7	-	SDV32...	1.87
SDV32-C32-416	32	416	G3/8"	10	-	SDV32...	2.64
SDV40-C40-408	40	408	G1/2"	7	-	SDV40...	3.88
SDV40-C40-528	40	528	G1/2"	10	-	SDV40...	5.16
SDV50-C50-518	50	518	G1/2"	7	RH-SDV50-SDV32	SDV32...	7.75
SDV50-C50-668	50	668	G1/2"	10	RH-SDV50-SDV40	SDV40...	10.26
SDV60-C60-628	60	628	G3/4"	7	RH-SDV60-SDV40	SDV40...	12.43
SDV60-C60-808	60	808	G3/4"	10	RH-SDV60-SDV40	SDV40...	16.14

SDV

SDV Anti-vibration Turning Tool Holder
SDV 阻尼减振车刀杆

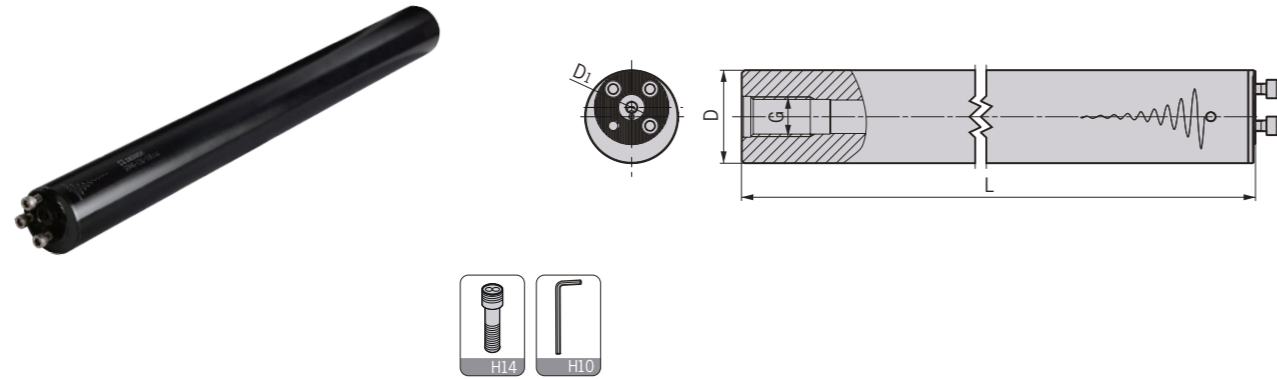

型号 Specification	D	D1	L	G	L/D	Dmin	适配刀头 Head	重量 Weight
SDV40-C50-518	50	40	518	G1/2"	7	60	SDV40...	7.77
SDV40-C50-668	50	40	668	G1/2"	10	60	SDV40...	10.28
SDV40-C60-628	60	40	628	G3/4"	7	70	SDV40...	12.43
SDV40-C60-808	60	40	808	G3/4"	10	70	SDV40...	16.14

SDV Anti-vibration Turning Tool Holder
SDV 阻尼减振车刀杆

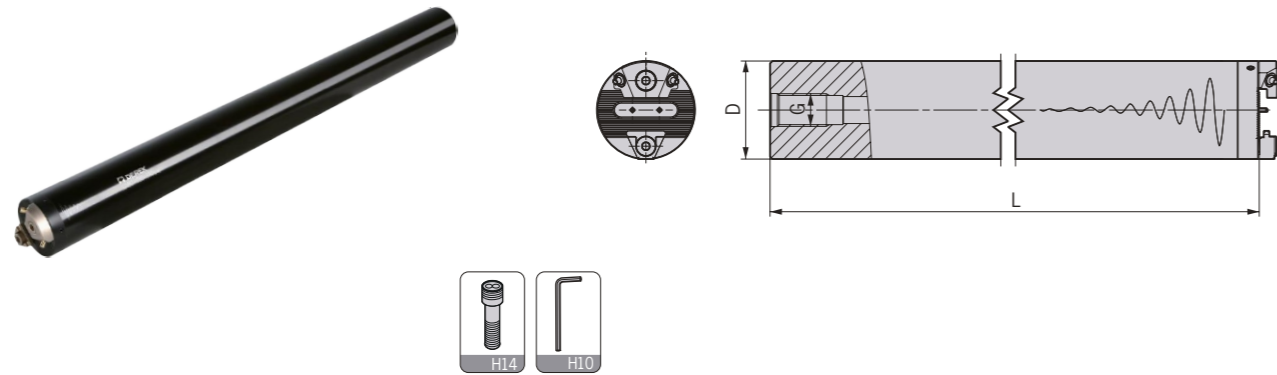

型号 Specification	D	L	G	L/D	适配刀头 Head	重量 Weight
SDV80-C80-880	80	880	G3/4"	7	SDV80...	32.80
SDV80-C80-1200	80	1200	G3/4"	10	SDV80...	45.00

SDV

Anti-vibration Reducing Head
阻尼减振车刀缩径头

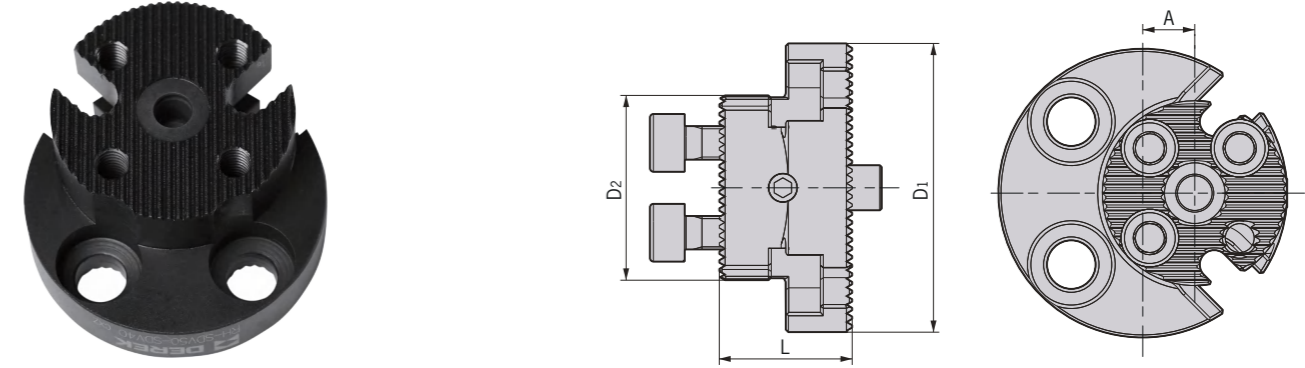

型号 Specification	D1	D2	L	A	重量 Weight
RH-SDV50-SDV32	50	32	23	9	0.17
RH-SDV50-SDV40	50	40	23	10	0.21
RH-SDV60-SDV40	60	40	23	10	0.29

Centre Calibration Block
中心校准块

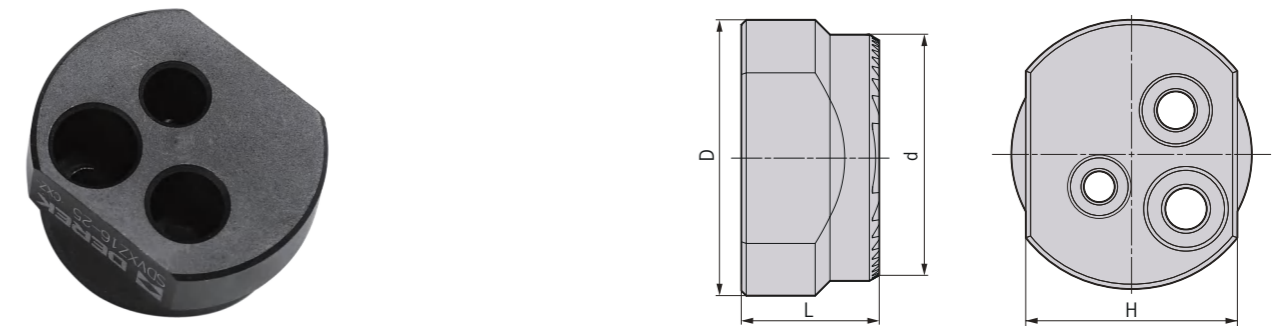

型号 Specification	D	d	H	L	适用刀杆 Holder	重量 Weight
SDVXZ16-25	28	25	22	14	SDV16/SDV20/SDV25	0.05
SDVXZ32-60	62	60	52	25	SDV32/SDV40/SDV50/SDV60	0.48

减振刀具安装及调整 / Assembly and adjusting

一、准备

Preparation

安装配合部位必须擦拭干净，如：减振刀杆及刀头V型定位槽、减振刀杆柄部外圆及安装座内孔，见下图 ① ② 两处示意位置。

Wipe clean the positions which need to be assembled, like V geometric slot on the cartridge and shank, the end of the shank which will be connected with adaptor, and internal hole on the clamping holder. See A and B position on the following visual.

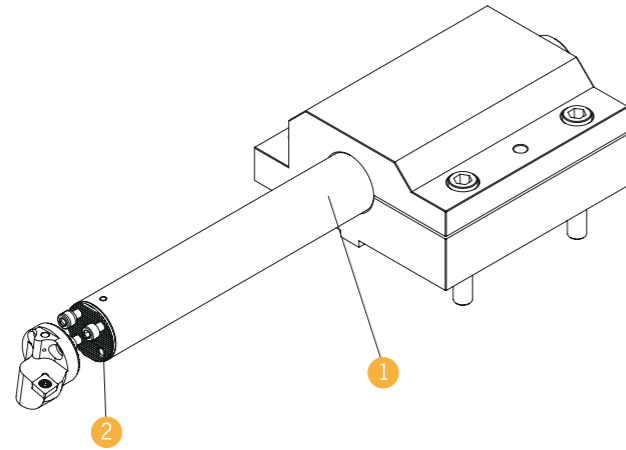

二、刀杆的安装

Assembly For The Shank

安装夹持长度不少于刀杆径的4倍，使用开口夹套等抱紧装夹方式，禁止使用螺钉直压等锁紧方式，长时间使用必须使用内冷却，如下图所示。

The clamping length should not be less than 4 L/D ratio. Suggest using the clamping cover with opening method and other holding clamping methods. Do not use screw clamping method. Use inner cooling please when working a long time.

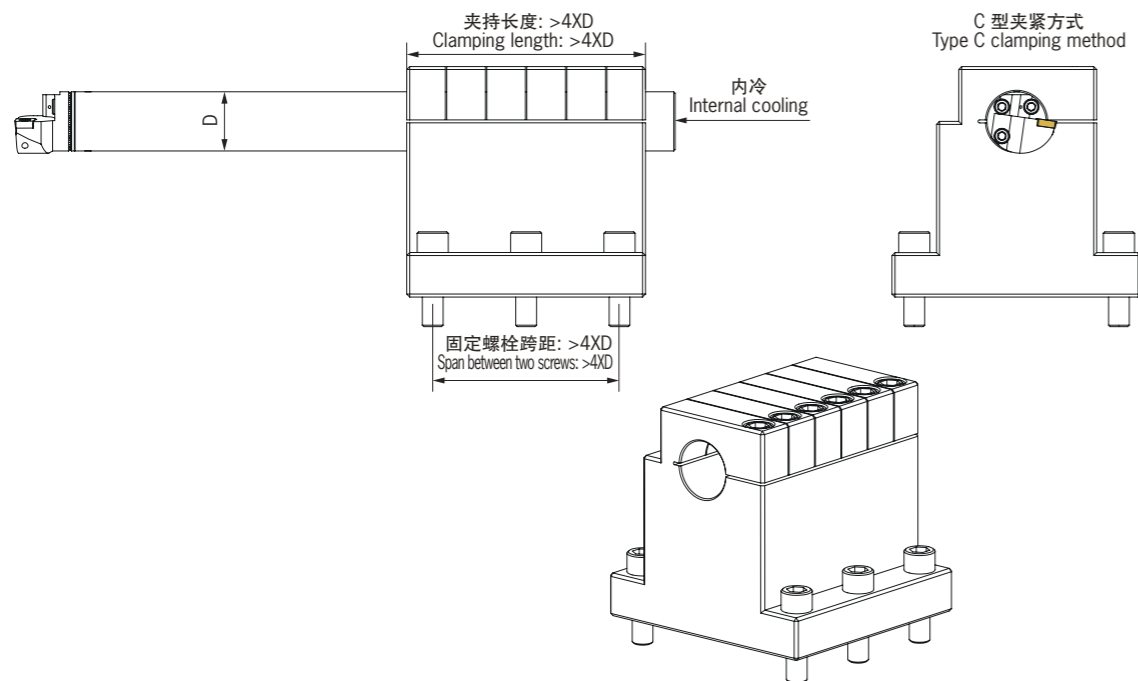

三、中心高调整

Adjusting The Height Of Centre

首次安装刀杆需要使用专用中心高校准工具，安装于车刀杆齿形槽接口处，锁紧，沿机床X轴方向校平基准平面0.01以内，锁紧刀杆后拆掉校准工具。

Exclusive calibration tool for the height of centre should be used when assembling the shank when the first time.

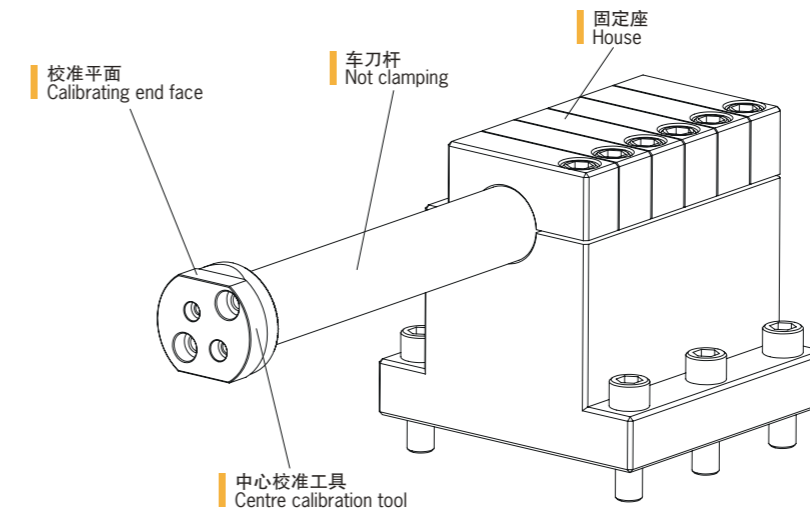

四、安装正确的车刀头

Assembly The Right Cartridge, See Below Figure

